



Shogun EB1 and EB3 eBike LCD Display

User Manual

Contents sections:

1. **Description** (Page 2)
2. **Daily User Guide** – User Level (Page 4)
3. **Configuration Settings** (wheel size specific) – Installer Level (Page 8)
4. **System Settings** (control system specific) – Advanced Level (Page 9)

Diagnostic and reference guide lists

1. Description

Product name and model

Shogun Bike LCD electric bike display (model: KD21C)

Specifications

- 24V/36V/48V Power Supply
- Rated current 10mA
- Maximum working current 30mA
- Off leakage current <1uA
- Operating temperature :-20°C~ 60°C
- Storage temperature: -30°C~ 70°C

Appearance and Size

Materials and Colour

- KD21C product's shell and fixing bracket are made of ABS and Nylon. The LCD window lens is made from hard acrylic. These materials are suitable for working in temperatures ranging between -20 and +60 oC.

Display appearance and dimensions: (unit: mm)

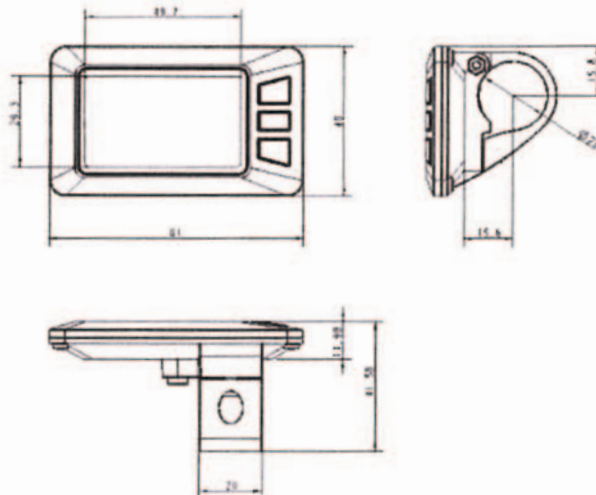

Summary of functions and Buttons

This display provides a host of useful functions and displays for Shogun Bikers:

- Battery charge level
- Power assist level
- Speed Display in MPH or KM/H
- Trip distance and cumulative distance
- 6km/h walk assistance / start assistance
- Front light switch

The advanced sections of this manual will explain how to first set-up and then tweak settings should the need arise, explaining:

- Error Codes
- Parameter Settings (for wheel size, speed-limiting, battery level tweaking, PAS relative level adjustments, controller current limits, adjustment for maximum speed, and even a password security feature.)

And if you ever get into a pickle this manual will show how to recover the default settings.

You shouldn't have to change any settings to fully enjoy riding your bike, and please be aware it is possible to spoil your fun completely by experimenting needlessly!

2. Using the display

The screen is best explained by a diagram...

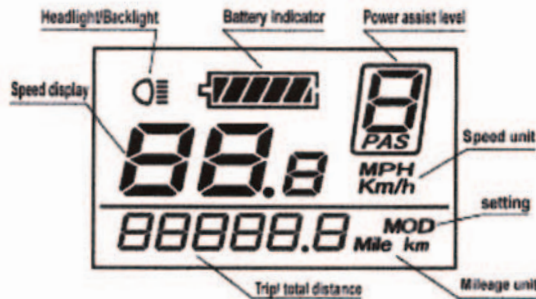

Just 3 buttons

We use just 3 buttons to both use and adjust the display. These are:



MODE, UP and DOWN

Before and during your rides

Power On/Off

Hold down the **MODE** button and the display will switch on and light up (if you've remembered to switch on your battery first...). Hold down the **MODE** button again and the display switches off. The display will also switch itself off if there's been no activity for 10 minutes.

Mileage Display

When first switched on the display will show the cumulative distance travelled. Press **MODE** to shift the display from total trip distance to trip distance.



Cumulative Distance Interface

Total Distance Interface

Walk assist mode

Press and hold the **DOWN** button for 2 seconds and your e-bike motor will start to run at a uniform speed of 6 Km/h and will continue to do so whilst you press that button. The display will show "P" on the screen whilst in this "Walk Assist" mode. When you release the **DOWN** button walk assist mode ends and the display reverts to as it was.

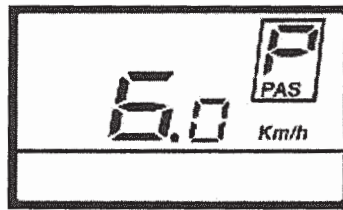

Walk Assist Mode

You should not be astride the bike when using walk assist.

Front Light (where applicable)

Press **UP** for 2 seconds to turn on the front light of your bike and also the backlight of the display. Hold **UP** again for 2 seconds and the light is turned off.

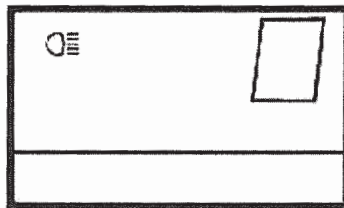

Turn On/Off Backlight

Power Assistance (PAS) Level Selection

Use the **UP** or **DOWN** buttons to change the assistance provided by your motor.

The default power ranges from level 1 to level 5. If you want to **switch off assistance** then use **DOWN** to reach level 0

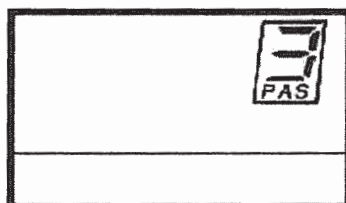

PAS Level 3

Battery Indicator

The battery bar shows the remaining capacity of the battery.

When a || the battery charge has been used its indicator will start to flash – you should definitely charge the battery when this happens.

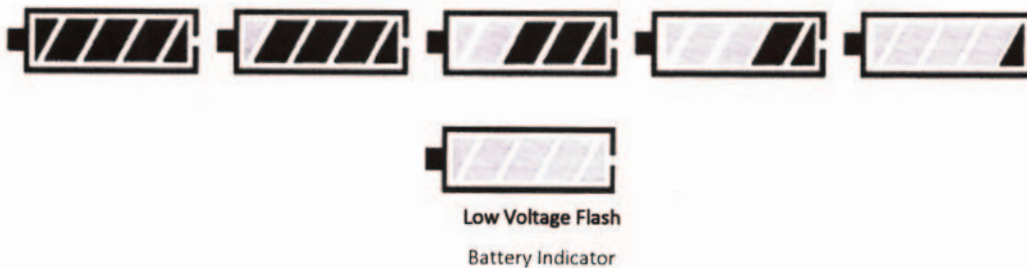

Charging the battery

To charge the battery, plug the charger into a wall socket. The LED on the charger unit should light red. Then plug the charger into the battery. The LED will remain red while the battery is charging. Once the battery is fully charged, the LED on the charger will turn green. Once fully charged, you should unplug the charger from the battery and wall right away. Never leave the battery charging for extended periods of time after charging is complete as this could cause overheating.

You can check the charge status during charging by turning on the display as described above, and checking the battery indicator status.

Error Code Information

The display can help enormously should there ever be a problem with any of the electrical components in the system. An error code will be displayed and a list of what these codes represent can be found later in this manual.



Error Code Indicator

3. Changing the settings

The display should arrive pre-configured and working properly for your bike. If you do need to change the way the display controls your bike then please do so sparingly, making a record of what you do and please bear in mind that some settings can make your bike no longer fully legal to ride in some countries. You may wish to change some settings to comply with local laws when travelling abroad.

General User Settings

- Any changes you make should be set **whilst the bike is at rest**.

Access the Settings

Hold **MODE** button to start the display, and then hold both **UP** and **DOWN** for 2 seconds to enter the **General User Settings Menu**. Then navigate through the following first level settings by tapping the **MODE** button.

Trip Distance Clearance

tC indicates single trip distance clearance settings.

Press **UP** or **DOWN** to choose Y or N to clear the current trip distance.

Then press **MODE** to confirm and exit.



Trip Distance Clearance Settings Interface

Backlight Contrast settings

bL indicates the contrast setting for the backlight.

Level 1 gives low brightness and Level 3 is high brightness.

Press **UP** or **DOWN** to modify the backlight brightness.

Press **MODE** to confirm and exit.

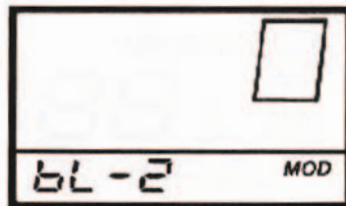

Backlight brightness Settings Interface

Imperial and Metric units

U indicates current unit settings. **1** is imperial (**Miles**) and **2** metric (**KM**).

Press **UP** or **DOWN** to change and press **MODE** to confirm and exit.

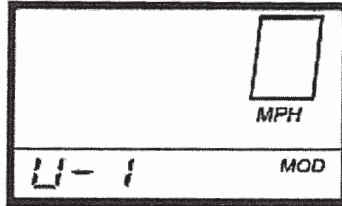

Inch and Metric Conversion Settings Interface

General Parameter Settings

Hold both **UP** and **DOWN** for 2 seconds enters User Settings, then hold both **MODE** and **DOWN** to access the following General Parameter Settings.

Wheel Diameter Settings

Ld indicates the settings for wheel diameter.

Selectable values include 16,18,20,22,24,26,700C and 28.

Press **UP** or **DOWN** to select the correct value to match the wheel diameter. The default diameter is 20 inch. Press and hold **MODE** to save and exit.



Wheel Diameter Settings Interface

Speed-limit Settings

LS shows the setting for the maximum assisted speed of the bike.

When the bike speed is faster than the limit speed, the display will ask the controller to gradually cut the motor power.

Limit speed range is 12Km/h to 40Km/h. Limit speed default value is 25Km/h.
Press **UP** or **DOWN** to select the desired value, and then hold **MODE** to save and exit.

PLEASE NOTE: Shogun Bikes have separate controllers which also limit the assisted speed to the legal requirements for the UK and Europe, so setting a faster speed will not enable the bike to be powered any faster. In fact, to avoid conflict with the controller we recommend the **LS** setting is set to maximum.

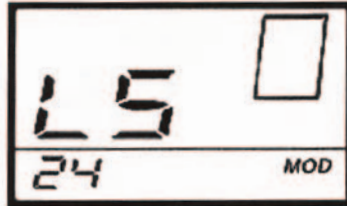

Limit Speed Settings Interface

4 (Very) Advanced Settings!

There are 8 settings in the **Advanced Settings** interface. None of these should need changing when the unit arrives and should only be altered by someone who fully understands their purpose. They are:

Battery Power Bar (**VOL**), Power Assistance Levels and Ratio (**PAS**), Over- Current Protection (**CUR**), Power Assistance Sensor Direction (**RUN**), Speed Sensor Sensitivity (**SCN**) and Magnet Number (**N**) and Sensor Number (**SPS**), Throttle Function (**HL**), System (**DLY**) and Power-on Password Settings (**P2**).

To access these advanced settings hold both **UP** and **DOWN** for more than 2 seconds to enter general settings, and then hold both **UP** and **DOWN** again to enter the Advanced Setting items selection page.

Press **UP** or **DOWN** to choose a setting, and then press **MODE** to enter its individual value page.

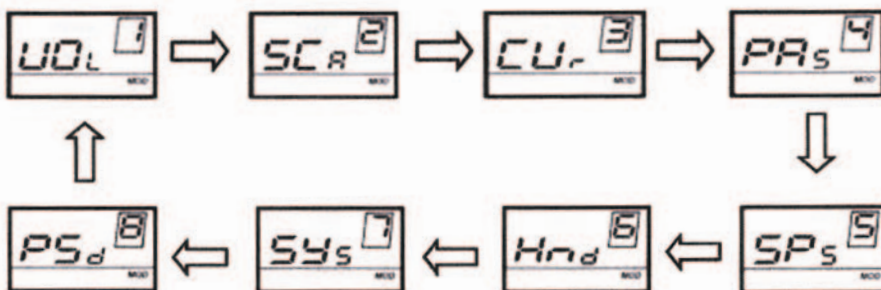

Option Select Interface

Battery Power Bar Settings

You should never need to change these settings.

VOL indicates the voltage setting for each of the five battery level displays.

Each bar represents a voltage value. 5 voltage values must be entered one by one.

VOL 1 is the **first** bar voltage value, normally set to **31.5 volts**. Press UP or DOWN to increase or reduce the value represented by the first bar. Press **MODE** to confirm and enter the second bar value. After all 5 voltage values have been entered, **hold MODE** to confirm and return to previous menu.

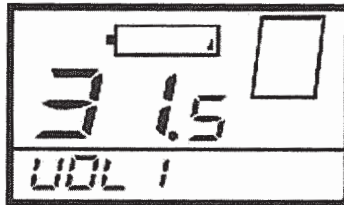

Battery Power Bar Settings

Power Assistance Level Settings

1. Power Assistance: Number of Levels

You can select **how many levels** of assistance are provided by the display.

You can choose to have **3, 5, 7 or 9** levels

Each range of levels may also include zero: **0-3 / 1-3**, or **0-5 / 1-5**, or **0-7 / 1-7**, or **0-9 / 1-9**. The default mode is 0-5 i.e. 5 increasing levels of assistance (and 0 for zero assistance). Press **UP** or **DOWN** to select your preference, then press **MODE** to confirm and enter the PAS ratio settings page. 5 levels normally works well, but choosing a higher number can give a better match for your own preferred rate of exercise while riding.

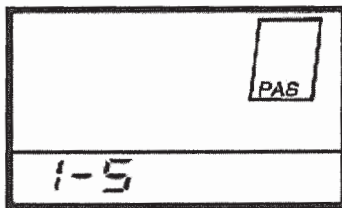

PAS Mode Select Interface

2. PAS Ratio settings

Each level of PAS can be set as a percentage value.

We recommend using **5 levels of assistance** with the values **50, 61, 73, 85 and 96**.

Use **UP** and **DOWN** to enter a value then Press **MODE** to confirm each value in turn.

After all the PAS ratios have been entered, **hold MODE** to confirm all values and return to the previous menu. (Other settings can be found in the attached list no. 3)

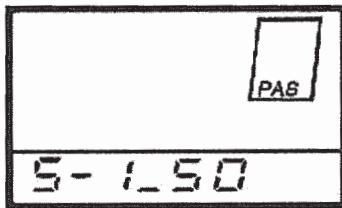

PAS Ratio Interface

Over-Current Protection Settings

CUR indicates the setting for protecting your bike from damage caused by over stressing its electrical components. The CUR value *can be* changed from 7.0A to 22.0A. But if you exceed 15A you are likely to damage your bike and you will also invalidate its warranty.

This value should remain set at no higher than 15A.

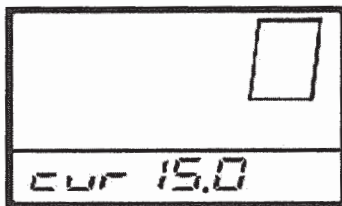

CUR Settings Interface

Power Assistance Sensor Settings

1. Setting the **Direction** of the Power Assist Sensor (PAS)

PAS refers to the power assist sensor settings. The first setting in this menu chooses the direction of rotation for the pedal sensor disk. "run-F" means **clockwise**, while "run-b" means **anti-clockwise**. Press **UP** or **DOWN** to select **F** or **b**, and press **MODE** to confirm and enter the setting. The default direction is "run-F" (When the pedals are turned forwards, the motor runs). It can be useful to change this setting if the Sensor Disk has been mistakenly reversed.



Direction of PAS Sensor Settings

2. Adjusting the **Sensitivity** of the PAS sensor

SCN shows the setting for the sensitivity of the pedal sensor. The values that may be used are from 2 (strongest) to 9 (weakest). The default value is 2 and this should pick up the signal from the sensor perfectly, but if less sensitivity is preferred choose a higher number.

Press **UP** or **DOWN** to change the pedal sensor sensitivity value, and then press **MODE** to confirm your choice.



The Sensitivity of PAS Settings

Once you have confirmed the SCN, pedal sensor sensitivity, you then need to confirm or change the number of magnets (N) in the PAS sensor plate (the black disk behind the pedal chain wheel).

3. **Number of magnets** on PAS plate

N refers to the number of magnets found on the PAS disk. Press **UP** or **DOWN** to select the correct quantity corresponding to your PAS plate. The default value is 6 but you may need to change this should you ever use a replacement plate.

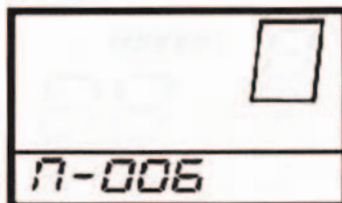

Number of PAS Magnets

Speed Sensor Selection

SPS refers to the number of sensors used by the display to measure the speed of rotation of the wheels. A Shogun Bike normally uses one sensor, concealed within its motor.

Press **UP** or **DOWN** to select the quantity of sensors (the range is from 1 to 9), and hold **MODE** to confirm and return to previous menu. The SPS default value is 1. On some occasions a value 8 is also valid for some Shogun Bike motors.

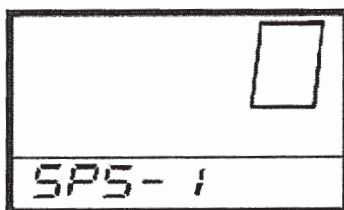

Speed Sensor Selection

Throttle Function

It's possible to have a throttle attached to your bike to work as a "start assist" aide.

HL indicates which mode the throttle (if attached) is configured. HL-Y indicates the throttle is restricted to 6KMH to help start from a standstill. This is the default value and to remain legal across the EU, this value should not be changed.

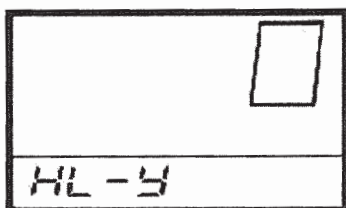

Throttle Enable/Disable Interface

System Settings

Delay time settings of battery power

DLY shows how often the battery voltage is monitored in real-time. Press **UP** or **DOWN** to select a frequency period of **3, 6 or 12s**, then press **MODE** to confirm. The default frequency is every 3s. It is sometimes useful to set a longer delay to overcome the effect of "voltage sag" when your bike motor is under increased load (setting off for instance) and when the voltage will drop briefly as a consequence. Normally though, 3 or 6 secs is a reasonable setting to use.

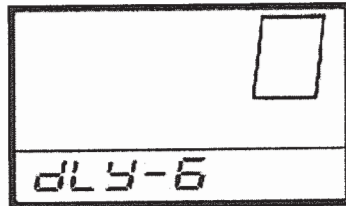

Delay time of battery power interface

2. Walk Assist Button

PUS refers to whether the **UP button** can be used to help when walking with the bike.

Press **UP** or **DOWN** to choose **Y** or **N**.

Y means walk assist is enabled when the UP button is held whilst walking alongside the bike.

The default value is **Y**.

Press **MODE** to confirm and enter both the above PAS speed settings.



Interface of PAS push

Walk Assist Speed Setting

Adjust the walk assist speed by pressing **UP** or **DOWN** to adjust from 20% to 35%, and then press **MODE** to confirm. The default value is 25%.



Walk speed ratio setting

Slow Start-up Setting

SSP sets how quickly the motor accelerates when the pedals are turned. The range is 1-4, where 4 is the slowest acceleration. Press **UP** or **DOWN** to choose, and then press **MODE** to confirm. The default value is 1. Sometimes this may be too quick for some riders.

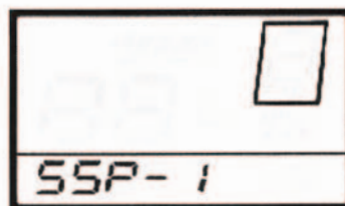

Motor acceleration

Power-on Password Settings

If a password has already been set, to secure your display, you will need to enter it at setting P2, in order to make any new changes to password settings. The default power-on password is 2222.

Press **UP** or **DOWN** to enter each digit in turn. Pressing **MODE** confirms each digit one by one. After the last digit, press **MODE** to confirm and then you can choose whether to enable the password.

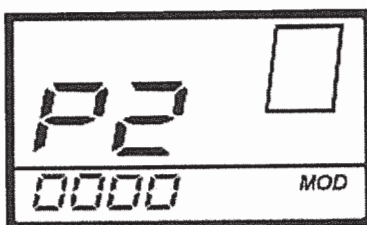

Power-on Password Screen

Power-on Password Enable

Press **UP** or **DOWN** to select Y or N, and press **MODE** to confirm. The default is N.

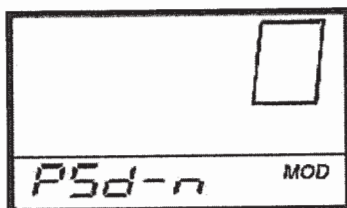

Power-on Password Enable Screen

Power-on Password Modify

When the display shows P3, 0000, press **MODE** to choose the new password digits one by one. Press **UP** or **DOWN** to input the new password, and then hold **MODE** to confirm the modification and exit settings.

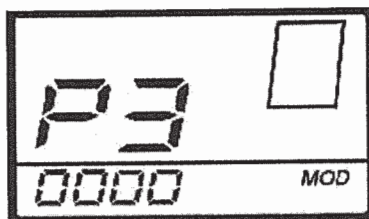

Power-on Password Modify

Restarting the display when the password is enabled will show P1,0000, ready for the rider to enter each new password digit in turn..

Exit settings

In the settings state, *pressing* **MODE** (for less than 2s) confirms the current input.

Holding **MODE** (for more than 2s) *saves* the new settings, and exits all settings.

Holding **DOWN** (for more than 2s) *Cancels* without saving any changed settings, and returns to the previous menu.

After one minute of inactivity the display will exit settings, without saving.

Recover default settings - *dEF*

Press both **UP** and **MODE** for more than 2 seconds to enter the recovery option.

Press **UP** or **DOWN** to choose Y (replace all settings with the default values) or N.

Hold **MODE**

The display then shows **DEF-00**, and will then return to its general display state.

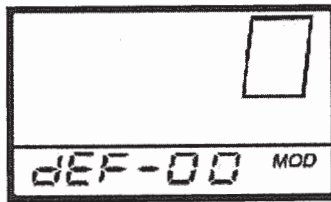

Recover Default Settings Screen

Safety notes:

- The Shogun Bike LCD Display is only for use with a compatible Shogun Bike model
- Always switch off all power at the main bike battery before disconnecting or re-connecting the LCD Display.
- Take particular care to line up the male connector plug of the display with the female plug on the bike. Check for the orientation arrows on each part and use minimal force.
- Position the display so that cables and connectors are not subjected to any strain, even when your handlebars are adjusted for riding or during
- Never attempt to dismantle the display
- Do not use your bike with power until any error code has been remedied

Warranty scope:

Standard Shogun Bike Warranty is applicable to cover for replacement in the event of faults arising from manufacturing defects subject to the display being used with due care as outlined above and for 12 months from purchase. See the Shogun Bike Website (www.bikecorp.com.au) for full terms.

Attached list 1: Error code definition

Error Code	Definition
21	Current Abnormality
22	Throttle Abnormality
23	Motor Abnormality
24	Motor Hall Signal Abnormality
25	Brake Abnormality
30	Communication Abnormality

Attached list 2: Personal Parameter settings

No	Settings item	Screen display
1	Battery Power Bar Settings	UD _L
2	Power assistant level Settings	SC _R
3	Over-current Cut Settings	CU _r
4	Power Assistant Sensor Settings	PA _S
5	Speed Sensor Settings	SP _S
6	Throttle Function Settings	HT _d
7	System Settings	SY _S
8	Power-on Password Settings	PS _d

Attached list 3: Power assist table

Level Level Item	1	2	3	4	5	6	7	8	9
0-3/ 1-3	50%	74%	92%	—	—	—	—	—	—
0-5/ 1-5	50%	61%	73%	85%	96%	—	—	—	—
0-7/ 1-7	40%	50%	60%	70%	80%	90%	96%	—	—
0-9/ 1-9	25%	34%	43%	52%	61%	70%	79%	88%	96%

Attached list 4: symbol definition

No.	Symbol	Definition
1	EE	Trip distance clearance
2	BL	Backlight
3	U	Unit
4	UOL	Voltage
5	Ld	Wheel diameter
6	LS	Speed limit
7	cur	Controller over-current cut
8	run-b	Backward
9	run-F	Forward
10	SCN	Sensitivity of PAS
11	SPS	Speed sensor
12	dLY	Power delayed time
13	HL	Throttle power assist walk
14	HF	Throttle-changing
15	PUS	Button push
16	SSP	Slowly start up
17	PSd	Password
18	DEF	Recover default
19	y	Yes
20	n	No